

Single Family Residential Patio Covers & Carports

How to Use this Guide

Provide two sets of plans and complete the following:

1. **Complete this Building Guide** by fill in the blanks on page two, and indicating which construction details will be used.
2. **Provide 2 Plot Plans** (site plan) showing dimensions of your project or addition and its relationship to existing buildings or structures on the property and the distance to existing property lines drawn to scale.
3. **Fill out a building permit application.**

The majority of permit applications are processed with little delay. The submitted documents will help determine if the project is in compliance with building safety codes, zoning ordinances and other applicable laws.



This handout was developed as a basic plan review submittal under the 2015 International Residential Code. It is not intended to cover all circumstances. Check with your Building Inspection Department for additional requirements.

City of Stillwater
Building Inspection Division
723 S Lewis St / PO Box 1449
Stillwater, OK 74076-1449

Single Family Residential Patio Covers & Carports

Directions

ADDRESS: _____

1. Fill in the blanks with dimensions and material which will be used to build the structure. Please print legibly.
2. Indicate in the check boxes which details from page 3 will be used. Please note if any of the sides of your carport addition are closer than 3'-0" to the property line, that side of the carport must be enclosed with a solid 1 hour fire rated wall as show in Alternate Details B and C. You must however, keep at least two sides of the carport open to conform to the building code requirements. Zoning approval is required.
3. Roofing to be installed per manufacturer's instructions, including low slope application and required inspections made

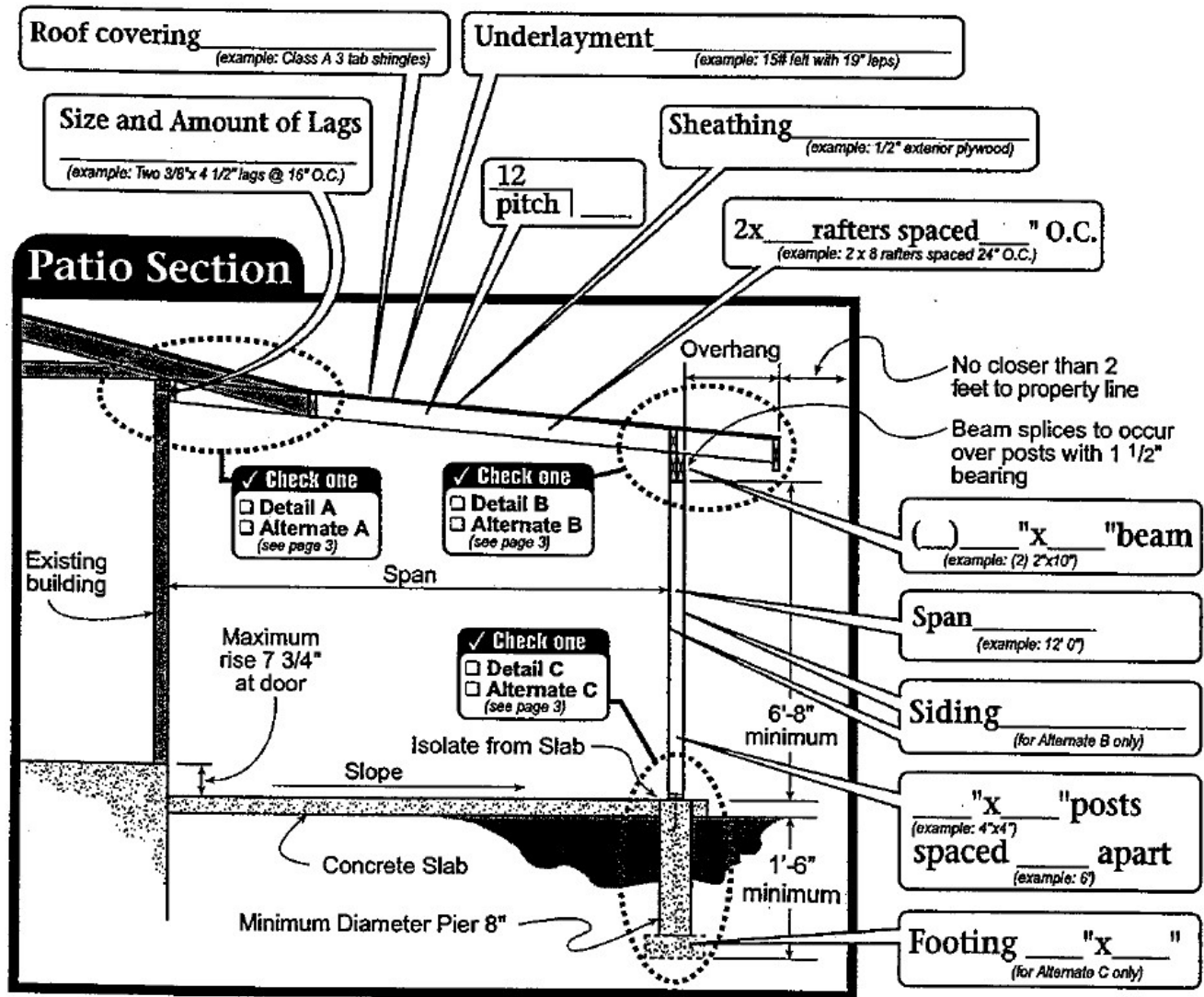

Single Family Residential Patio Covers & Carports

Detail A

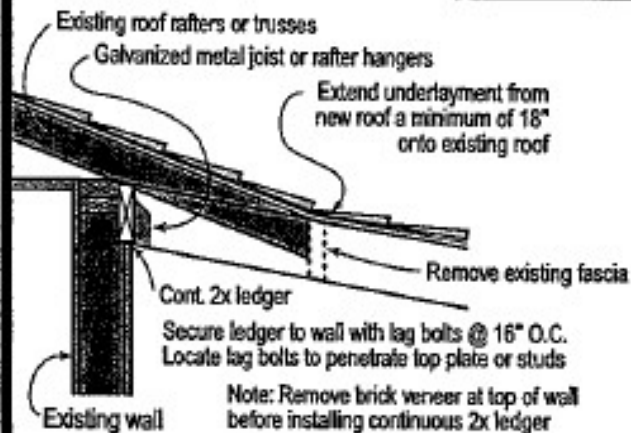

Alternate Detail A

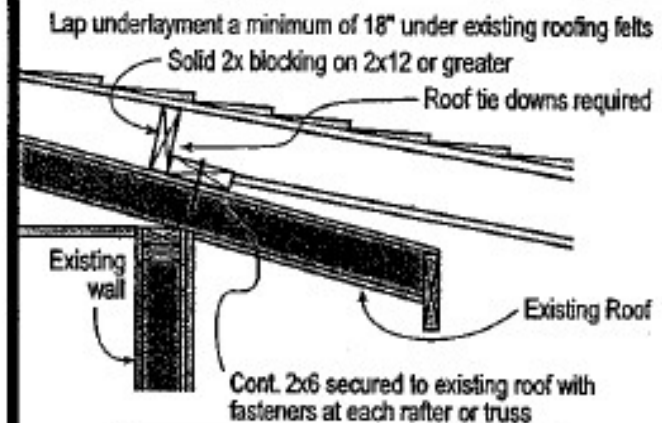

Detail B

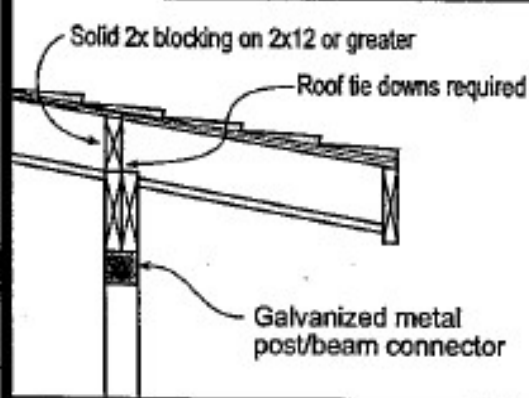

Alternate Detail B - 1 Hour Wall - (if closer than 3' to existing building)

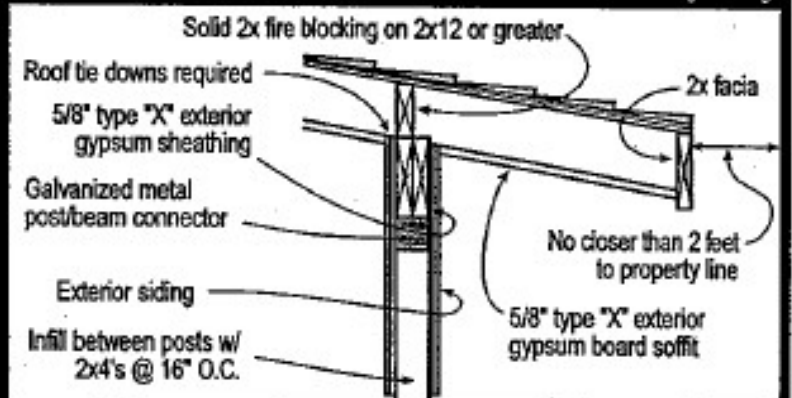

Detail C

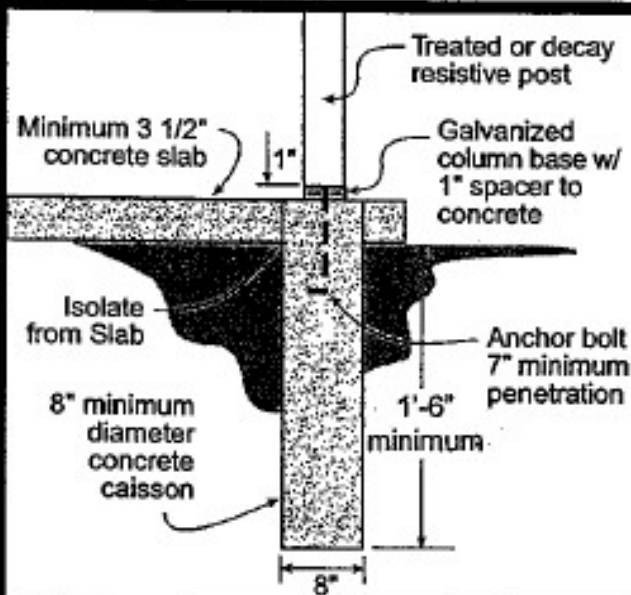

Alternate Detail C - 1 Hour Wall

